

**PRO2 series – Short reference**

Congratulations on choosing a Rainbow Colour Changers product! We thank you for your custom. Please note that this product has been designed and made with total quality to ensure excellent performance and best meet your expectations and requirements.

It is essential to know the information and comply with the instructions given in this manual in order to ensure the fitting is installed, used and serviced correctly and safely.



**Carefully read this instruction manual in its entirety and keep it safe for future reference!** Please hand this manual over if you sell or give this product to somebody else.



### General

- Rainbow Colour Changers products are intended for professional use and should only be used by qualified personnel or under their supervision.
- Follow all cautions and warnings indicated on the unit.
- After unpacking this product, please check if the device is intact. If this is not the case, please contact the support service.

**Rainbow Colour Changers**  
An der Talle 26-28  
D-33102 Paderborn, Germany  
Phone: +49 (0)52 51/14 092-28  
Fax: +49 (0)52 51/14 092-90  
info@rainbow-colour-changers.de

### Installation

- Make sure all parts for fixing the colour changer are correct.
- Make sure the fixture is stable before positioning the Colour Changer.
- Do not fix this device on or near flammable surfaces.

### Usage

- This product is designed for indoor use only. For the fitting to operate well and reliably, it should not be used in humid environments. The ambient temperature should not exceed 40°C (104°F) or fall below 0°C (32°F).
- Avoid any liquids or metallic items entering the unit.
- Ensure adequate ventilation and do not block or cover any ventilation slots in the device – they guarantee the reliable functioning of the unit and protect it against overheating.
- The scroller may only be used in its standard position, which is +/- 60° from horizontal.
- The colour changer may only be put into operation with original Rainbow Colour Changer power supply units (PSU).
- Check that the mains frequency and voltage correspond to those for which the PSU is designed as given on the surface label of the PSU. Refer to the manual about the max. amount of scrollers to be connected

### Maintenance

- All service work should be exclusively performed by qualified personnel.
- Do not dismantle the scroller or modify it yourself.
- Before starting any maintenance work or cleaning the scroller, remove the power from the PSU.
- The surface of the device may heat up due to the luminaire used. Please let the scroller cool down before touching it.

Rainbow Colour Changers GmbH disclaims all liability for damage to the fitting or to other property or persons deriving from installation, use and maintenance that have not been carried out in conformity with this instructions manual, which must always accompany the fitting.

Rainbow Colour Changers GmbH reserves the right to modify the characteristics stated in this instructions manual at any time and without prior notice.

## Cutting Gels PRO2 Range

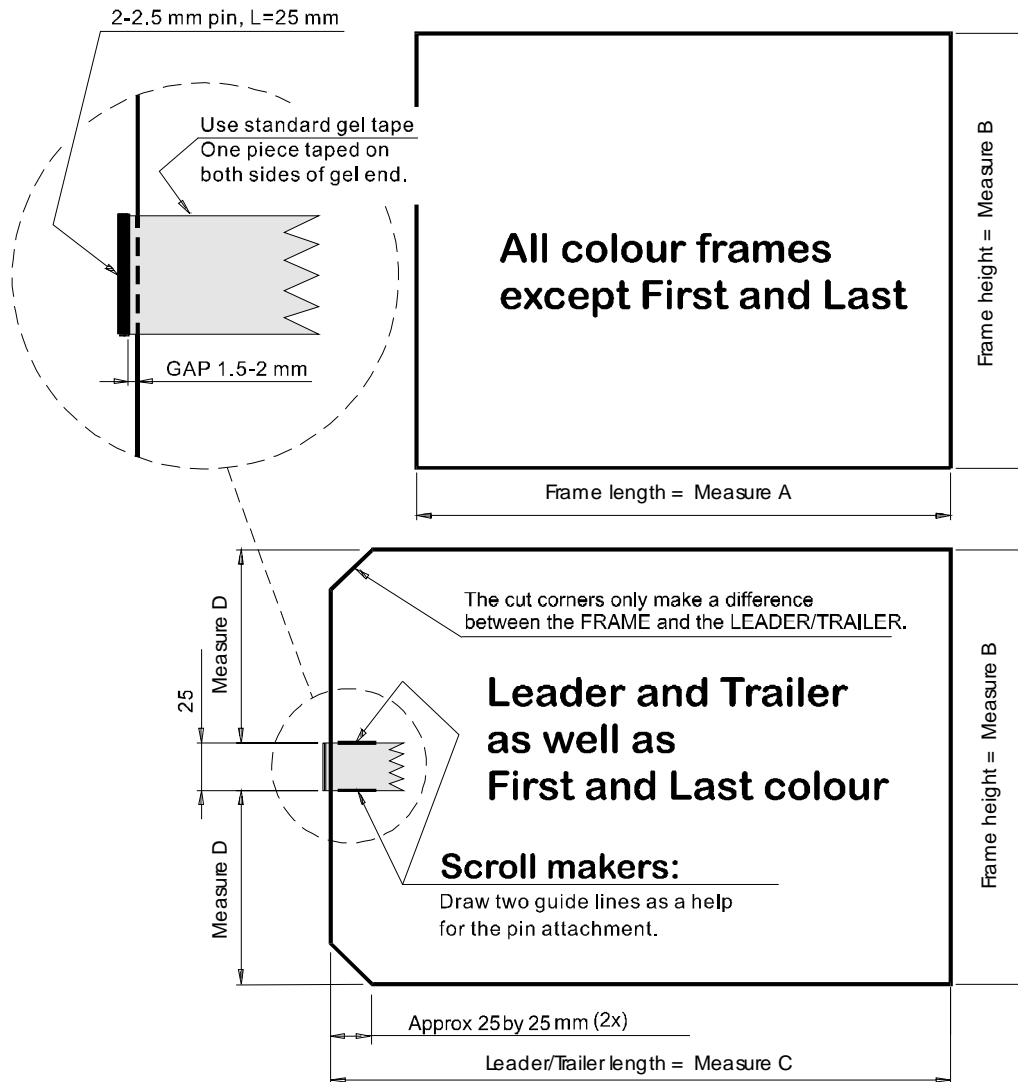

The whole scroll MUST be straight and tape sticking out MUST be cut.

Colour Changer	Measure A	Measure B	Measure C	Measure D
6" PRO2	220 mm	168 mm	265 mm	71,5 mm
8" PRO2	280 mm	228 mm	325 mm	101,5 mm
12" PRO2	370 mm	318 mm	415 mm	146,5 mm
15" PRO2	560 mm	410 mm	660 mm	192,5 mm
8-Lite PRO2	560 mm	640 mm	660 mm	307,5 mm

## Location of LED-display and DMX ports

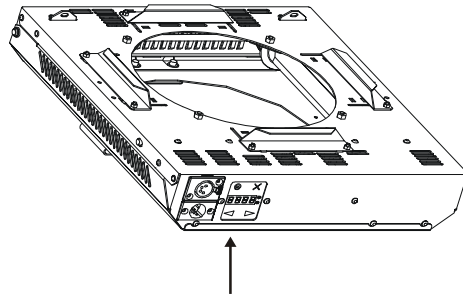

## LED-Display and DMX ports

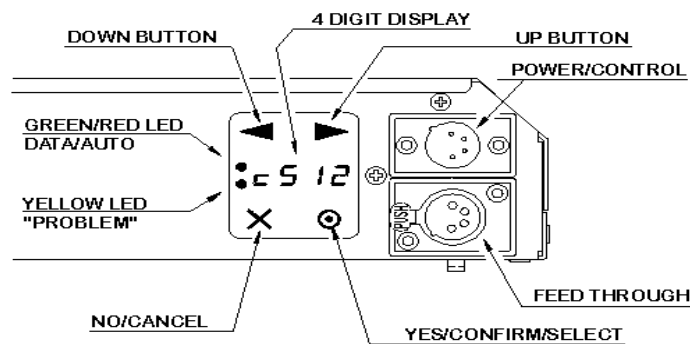

## Opening the unit

Place the unit lying on its back on a table with the scroller's front facing up and the display facing you. Open the lid of the unit by pressing the spring-loaded locking pins on each side and lifting the lid upwards as shown in the figure .

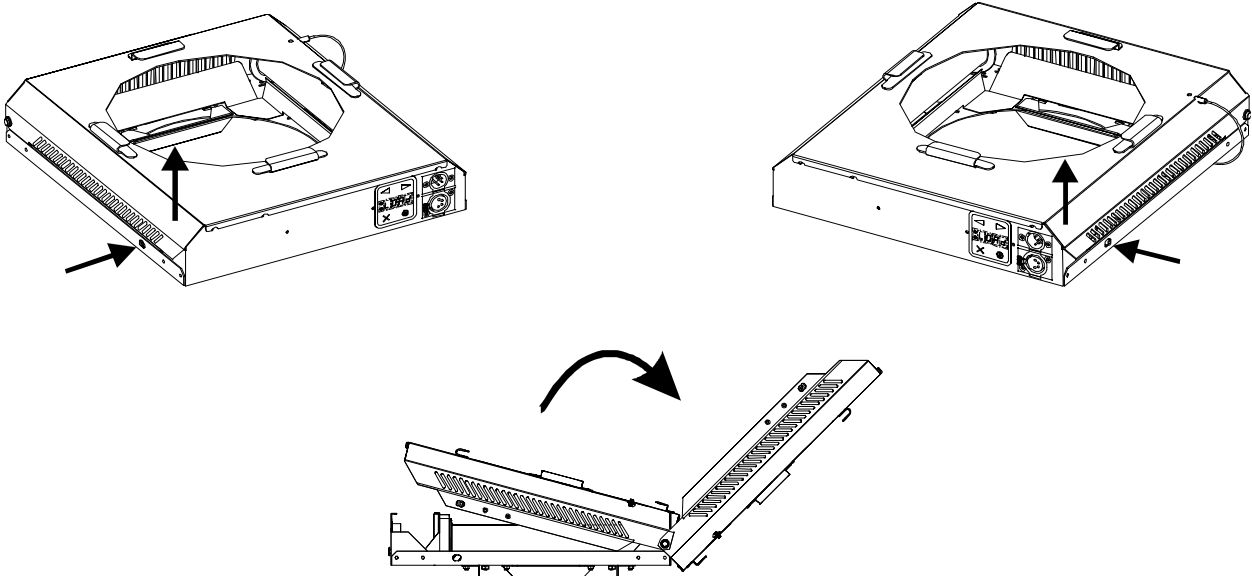

## Scroll load and power up the Scroller

### Loading the gel string:

The gel string has to be cut exactly to the measurements for the scroller for proper operation. The delivered Gel Attachment Pins should be fixed at the beginning and the end.

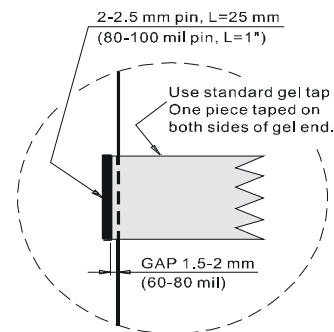

The heat resistant tape for connecting the single colour frames has to be on the side which turns away from the luminaire. The Colour Changer should be placed opened (see „Opening the scroller“), with the display facing you. Connect the scroller with the power supply and switch it on.

Step	Key/Sequence	Action	Display (?- for individual value)	Display/ action
1.		Turn on the power	<i>boot</i> <i>3.023</i>	Appears after powering up actual software- version (example)
			<i>Pr.B</i>	scrollertype (example)
			<i>Lodd</i> <i>-00-</i>	Alternate flashing with Amount of colours
2.	⊙	Press	<i>□--□</i>	Scroller drives to the home position
			<i>Jo in</i>	When it is at its home position
3.	⊙	Insert the colour string	<i>roll</i>	

Lay down the gel string on the right hand side of the scroller, so that the string is aligned between the flanges of the right roll. Please note that the colour string is running between the leaders at the side of the rolls. Turn the left roll until the slot faces upwards.

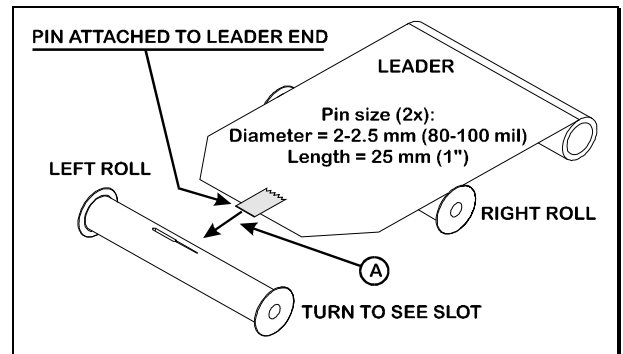

Slide the pin of the start gel leader into the slot of the left roll (B) and centre the colour string in the middle of the roll (C), so that the leaders at the side of the rolls do not have any touch with the colour string.

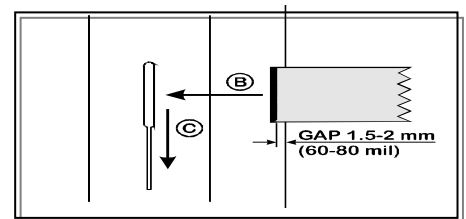

Fix the edges of the colour string with the help of the heat resistant tape.

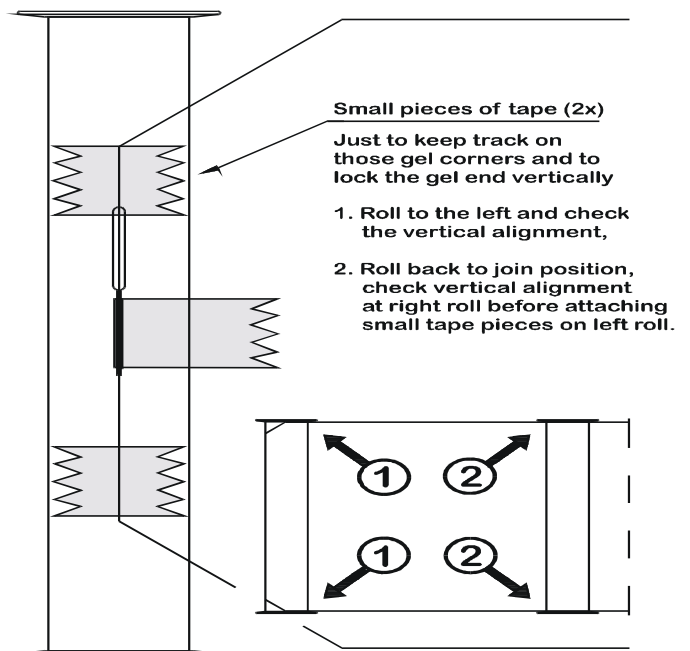

Step	Key/Sequence	Action	Display (?- for individual value)	Display/Action
4.	◀	Press	roll	Gel string rolls forward
5.	▶	Press	roll	Gel string rolls back
6.		At the end position tension the roll and fix the gel string		

Stop when the end gel string trailer is over the right roll. Pull the end gel string trailer lightly to tighten the wound up gels on the right roll. have to tension the right roll.

Depending on the number of single frames, you have to tension the right roll:

For 6", 8" and 12" PRO2 Colour Changer:

- 2 – 21 colours = 6 full turns
- 21 – 25 colours = 7 full turns (for the 12" PRO2)
- 21 – 33 colours = 7 full turns

For 15" and 8-Lite PRO2 Colour Changer:

- 11 – 16 colours = 18 full turns
- 17 – 20 colours = 20 full turns
- 21 – 25 colours = 20 full turns

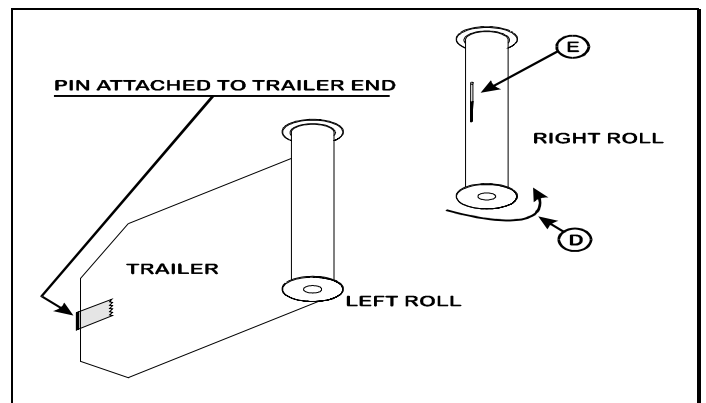

Tension the right roll by turning it anti-clock-wise. After the correct quantity of full turns hold the roll (the slot has to face up) and fix the colour string by attaching the gel attachment pin into the slot of the right roll. Release the roll carefully and check with the help of rolling forward and back with the following keys ▶ ◀ the correct guide of the colour string. Now fix the edges of the gel string with the heat resistant tape.

The automatic pre-calibration and the pre-run of the colour string follows at this point. This is necessary for a precise rolling-up, because the Colour Changer automatically calculates the number of colour frames.

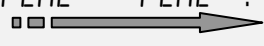
Step	Key/Sequence	Action	Display (?- for individual value)	Display/Action
7.	⊙	Press	PCAL and 05	Alternate Flashing
		Scroller starts automatically preruns and precalibration		
			PCAL - PCAL ? 	Counts pre-run reverse from 05 to 01
if wanted	⊙		PCAL?	Early interruption of the pre-runs (possible right after the start at 05)
		End of pre-run	CAL	Calibration is running
		End of calibration	-??-	Flashing display: Amount of calculated colour frames
if needed	◀ ▶	Press (if the calculated number of colour frames is wrong)	-??-	Reduces/increases the amount of colours (max. 2 possible)
8.	⊙	Press (confirmation of colour amount)	-??-	confirm
9.			c001	Colour control address
				End of loading procedure

After finishing the gel string load procedure, the scroller automatically runs to the actual DMX value of DMX channel 001 (c001) right after the definition of the position, the fan will be started and the scroller is ready to be used.

### Load the colour string (overall view):

Step	Key/Sequence	Action	Display (?- for individual value)	Display/Action
1.		Powering up the scroller	<i>boot</i> <i>3.023</i> <i>Loadd</i> <i>-??-</i>	Appears after powering up Software version (example) Flashing display
2.	⊙	Press	<i>0--0</i> <i>00 00</i>	Scroller is running to the start position
3.	⊙	Insert the gel string	<i>roll</i>	
4.	◀	Press	<i>roll</i>	Gel string runs forward
5.	▶	Press	<i>roll</i>	Gel string runs back
6.		Gel string at the end position: Tension the roll and fix the gel string		
7.	⊙	Press	<i>PCAL</i> and <i>05</i>	Flashing
		Scroller starts automatically preruns/precalibration		Counts preruns reverse from 05 to 01
if wanted	⊙	Press	<i>PCAL</i>	Early interruption of the pre-runs (possible right after the start at 05)
		End of pre-calibration	<i>CAL</i>	calibration
		calibration	<i>CAL</i>	calibration
		End of calibration	<i>-??-</i>	Number of the colour frames
if needed	◀	Press (if the calculated number of colour frames is wrong)	<i>-??-</i>	Reduces the amount of colours (max. 2 possible)
if needed	▶	Press (if the calculated number of colour frames is wrong)	<i>-??-</i>	Raises the amount of colours (max. 2 possible)
8.	⊙	Press	<i>-??-</i>	
9.			<i>c00 1</i>	Confirm
				Start address End of the loading procedure

## Start address

### Addressing

The start address always refers to the colour change. You can adjust the channels for fan- and motor-remote control individually.

Key/Sequence	Action	Display (?- for individual value)	Display/Action
⊙	Press and hold until	▢???	Flashing
◀	Press or hold	▢???	Count downwards
▶	Press or hold	▢???	Count upwards
⊙	Press	▢???	Confirmation of new address
×	Return to the prior menu		

## Gel positioning

### Full- and Halfcolour mode (Frame by Frame)

Key/Sequence	Action	Display (?- for individual value)	Display/Action
× ◀ ◀ ◀	Press in succession	FbF.?	
		<b>Mode</b>	<b>Colour mode</b>
		FbF.□	Out (free positioning)
		FbF.H	Halfcolour mode
		FbF.F	Fullcolour mode
Key/Sequence	Action	Display (?- for individual value)	Display/Action
⊙	Press	FbF.?	Flashing
◀	Press	FbF.?	Count modes downwards
▶	Press	FbF.?	Count modes upwards
⊙	Press	FbF.?	Confirmation of new mode
×	Return to the prior menu		

A dot running from left to right within the address display indicates fullcolour mode. The halfcolour mode will be indicated by a dot sequence (1-2) within the address display.

The FbF mode is from software version 3.xx onwards also choosable via the control channel.

## General functions

### Key functions during powering up the scroller

Key/Sequence	Action during the procedure of power up	Display (?- for individual value)	Display/Action
◀ ▶	Press and hold both keys while powering up the scroller	Load -00-	Reset to factory parameters incl. information „no gel string is loaded“
▶	Hold while powering up the scroller	Loc	Locks the Scroller
▶	Hold while powering up the scroller	uLoc	Un-locks the Scroller

### Information display

Display	Meaning
USED	Chosen address is already used by the scroller
H 1-C	Colour address is outside the available DMX-sector
H 1-S	Motor address is outside the available DMX-sector
H 1-F	Fan address is outside the available DMX-sector
H 1-r	Remote address is outside the available DMX-sector

### LED-display

LED-Display	Meaning
green	Valid DMX signal is on
red	Scroller is running in auto-mode
yellow	Problem, but the scroller is still working
Alternating red/green	Error, Scroller does not work any longer Press × for abortion

### LED's in the display

Display	Meaning
Small dot	Display is switched off, DMX is on
Small dot, flashing	Display is switched off, no DMX
Dot is running from left to right	Fullcolour mode
Dot sequence (1-2) is running from left to right	Halfcolour mode

## Fan control

### Adjustment of fan speed

Key/Sequence	Action	Display (?- for individual value)	Display/Action
× ◀	Press in succession	<i>Fbn.?</i>	
		<b>Mode</b>	<b>Fan speed</b>
		<i>Fbn.0</i>	Out
		<i>Fbn.L</i>	Low
		<i>Fbn.H</i>	Half
		<i>Fbn.F</i>	Full
		<i>Fbn.d</i>	Speed is adjustable via DMX
Key/Sequence	Action	Display (?- for individual value)	Display/Action
⊙	Press	<i>Fdn.?</i>	Flashing
◀	Press	<i>Fdn.?</i>	Counts modes downwards
▶	Press	<i>Fdn.?</i>	Counts modes upwards
⊙	Press	<i>Fdn.?</i>	Confirmation of new mode
×	Return to the prior menu		

### Adjustment of the DMX-address for fan speed

Key/Sequence	Action	Display (?- for individual value)	Display/Action
		<i>Fdn.d</i>	
⊙	Press	<i>F.???</i>	Flashing
◀	Press	<i>F.???</i>	Counts downwards
▶	Press	<i>F.???</i>	Counts upwards
⊙	Press	<i>Fdn.d</i>	Confirmation of new mode
×	Return to the prior menu		

## Motor control

### Adjustment of motor speed / gel speed

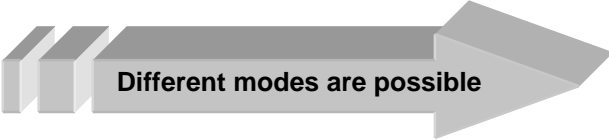
Key/Sequence	Action	Display (?- for individual value)	Display/Action
× ◀ ◀	Press in succession	SPd.?	
		<b>Mode</b>	<b>Motor speed</b>
		SPd.0	Out
		SPd.L	Limited internal
		SPd.d	Speed is adjustable via DMX
Key/Sequence	Action	Display (?- for individual value)	Display/Action
⊙	Press	SPd.?	Flashing
◀	Press	SPd.?	Counts downwards
▶	Press	SPd.?	Counts upwards
⊙	Press	SPd.?	Confirmation of new mode
×	Return to the prior menu		

### Adjustment of internal limit for motor speed

Key/Sequence	Action	Display (?- for individual value)	Display/Action
		SPd.L	
⊙	Press	L ??	Flashing
◀	Press	L ??	Counts downwards in 5% steps
▶	Press	L ??	Counts upwards in 5% steps
⊙	Press	SPd.L	Confirmation of new mode
×	Return to the prior menu		

Adjustment of DMX-address for motor speed

Key/Sequence	Action	Display (?- for individual value)	Display/Action
		SPd.d	
⊙	Press	5.???	Flashing
◀	Press	5.???	Counts downwards
▶	Press	5.???	Counts upwards
⊙	Press	SPd.d	Confirmation of new mode
×	Return to the prior menu		

All Colour Changers of the PRO2 Range offer extensive functions with regard to configuration and special features, which are being operated via the integrated 4-figure LED display. An external power supply is required for operation.

### 6" PRO2 Colour Changer

The extremely compact 6" PRO2 Colour Changer suits all smaller luminaires with a front aperture of up to 127 mm, especially the ETC Source 4. The Colour Changer is mounted to the luminaire via an adaptor plate with integrated heatshield (Rosco heatshield), which is available in 2 different sizes. The operation without heatshield reduces the durability of the colour string considerably and is not recommended. The unit can run up to 33 single colours. The operation and menu guide is nearly the same for all PRO2 Colour Changers. (Please find all details in the Operator's manual.)

An external power supply is required for operation. The Scroller is delivered with heatshield adaptor and safety cable. Data cable, power supply and colour string are not included.

Technical data		Art.No.	Description
Adaptor sizes:	159 x 159 / 190 x 190 mm	RCC3601A	6" PRO2 with heatshield adaptor 159x159 mm (6,25") incl. heatshield
Maximum number of colours:	33	RCC3601B	6" PRO2 with heatshield adaptor 190x190 mm (7,5") incl. Heatshield
Start-to-end string movement:	2,9 s	060990	Colour String, 33 colours for 6" PRO2
Front aperture Ø:	154 mm	060974	Colour String, 16 colours for 6" PRO2
Rear aperture Ø:	127 mm	060973	Colour String, 11 colours for 6" PRO2
Power/data Connector style:	XLR4	020641	Barndoor for 6" PRO2
Weight:	1,9 kg	RCC2016	Heatshield adaptor 159x159mm (6,25") incl. Heatshield
Measurements:	285 x 243 x 87 mm	RCC3616	Heatshield adaptor 190x190 mm (7,5") incl. Heatshield
Supply voltage:	24 V (PSU)		

## 8" PRO2 Colour Changer

The 8" PRO2 Colour Changer suits all medium-size luminaires with a front aperture of up to 192 mm. The Scroller is mounted via an universal adaptor, that can be adjusted to a variety of different standard sizes. The unit runs up to 33 single colours with extremely smooth colour changes and most precise positioning thanks to the high resolution of the built-in electronics. The operation and menu guide is nearly the same for all PRO2 Colour Changers. (Please find all details in the Operator's manual.) An external power supply is required for operation. The Scroller is delivered with universal adaptor and safety cable. Data cable, power supply and colour string are not included.

Technical data		Art.No.	Description
Adaptor sizes:	185, 190, 198, 210, 215, 230, 240, 245, 255 mm	RCC3001 RCC3056 RCC3057	Colour Changer 8" PRO2 New Universal Adaptor for 8" PRO2 Set of 4 cranked hooks for Uni. Adaptor
Maximum number of colours:	33	060989	Colour String, 33 colours for 8" PRO2
Start-to-end string movement:	3,6 s	060976	Colour String, 16 colours for 8" PRO2
Front aperture Ø:	215 mm	060975	Colour String, 11 colours for 8" PRO2
Rear aperture Ø:	192 mm	010823	Barndoor for 8" PRO2
Power/data Connector style:	XLR4	RCC3616	Heatshield adaptor 190 x 190 mm (7,5"), incl. Heatshield
Weight:	2,2 kg	060922	Heatshield for 8" PRO2
Measurements:	333 x 303 x 87 mm		
Supply voltage:	24 V (PSU)		

## 12" PRO2 Colour Changer

The 12" PRO2 Colour Changer suits nearly all larger luminaires up to 2,5 KW with a front aperture of up to 266 mm. The Scroller is mounted via an universal adaptor that can be adjusted to a variety of standard sizes. The 12" PRO2 can run up to 25 single colours, while the high resolution of the built-in electronics guarantees for extremely smooth colour changes and most precise positioning. An external power supply is required for operation.

The unit is delivered with universal adaptor and safety cable. Data cable, power supply and colour string are not included.

Technical data		Art.No.	Description
Adaptor sizes:	240, 245, 255, 270, 275, 285, 290, 295, 300, 305 mm	RCC3801 RCC3822	Colour Changer 12" PRO2 New Universal Adaptor for 12" PRO2
Maximum number of colours:	25	060991	Colour String, 25 colours for 12" PRO2
Start-to-end string movement:	3,5 s	060978	Colour String, 16 colours for 12" PRO2
Front aperture Ø:	304 mm	060977	Colour String, 11 colours for 12" PRO2
Rear aperture Ø:	266 mm	060920	Barndoor for 12" PRO2
Power/data Connector style:	XLR4		
Weight:	2,9 kg		
Measurements:	416 x 393 x 87 mm		
Supply voltage:	24 V (PSU)		

## 15" PRO2 Colour Changer

The 15" PRO2 Colour Changer suits bigger, high-performance luminaires with a front aperture of up to 380 mm. It can run up to 25 big-size single colour frames. The Scroller is mounted via an universal adaptor plate with round aperture, which can be adjusted to many standard sizes. The complete front and back bodies can be exchanged in order to enable the combination with a 4-Lite Blinder or the mounting of accessories of various manufacturers.

The 15" PRO2 Colour Changer for 4-Lite Blinder shows a square aperture on front and back. This unit comes with mounting adaptors for variable mounting possibilities onto a 4-Lite Blinder. The Scroller can be mounted horizontally for vertical scrolling.

**The only difference with regard to the operation of the Scroller in comparison to the other PRO2 Colour Changers is the tensioning of the colour string – see page 6.**

An external power supply is required for operation. Data cable, power supply and colour strings are not included in the delivery specification.

Technical data		Art.No.	Description
Universal adaptor sizes 15" PRO2:	313, 322, 343, 355, 360, 370, 382, 396, 402, 412 mm	RCC5000 RCC5070	Colour Changer 15" PRO2 Front with square aperture 15" PRO2
Front aperture Ø:	380 mm	RCC510	Adaptor for Thomas 4-Lite Blinder
Rear aperture Ø:	380 mm	RCC5010/4L	Colour Changer 15" PRO2 for 4-Lites (incl. square front + adaptor for Thomas 4-Lite)
Measurements 15" PRO2:	519 x 600 x 98 mm		
Weight 15" PRO2:	8,5 kg		
Adaptor sizes 15" PRO2 f. 4-Lites:	400 x 400 mm	RCC505 RCC5060	Universal adaptor for 15" PRO2 15" PRO2 Front plate with round aperture and universal adaptor for 5K barndoor
Front aperture Ø:	395 mm	060993	Colour String, 25 colours for 15" PRO2
Rear aperture Ø:	395 mm	060982	Colour String, 16 colours for 15" PRO2
Meas. 15" PRO2 f. 4-Lites:	520 x 570 x 95 mm	060985	Colour String, 11 colours for 15" PRO2
Weight 15" PRO2 for 4-Lites:	6,2 kg		
Maximum number of colours:	25		
Start-to-end string movement:	6,4 s		
Power/data Connector style:	XLR4		
Supply voltage:	24 V (PSU)		

## 8-Lite PRO2 Colour Changer

The 8-Lite PRO2 Colour Changer for 8-Lite Blinders corresponds with the other PRO2 Colour Changers in terms of operation, configuration and nearly all other functions. (Please find all details in our Operator's manual.) **You will find the only difference in tensioning the colour string – see page 6.**

The Scroller has a square aperture for 8-Lite Blinders. It can be mounted to Major 8-Lite Blinders without further accessories, while different adaptor versions for other types of 8-Lite Blinders are available.

The unit is delivered with safety cable for the front; but without data cable, power supply and colour string.

Technical data		Art.No.	Description
Universal adaptor sizes:	388 x 680 mm	RCC4100	Colour Changer 8-Lite PRO2
Maximum number of colours:	25	060992	Colour String, 25 colours for 8-Lite PRO2
Start-to-end string movement:	7 s	060986	Colour String, 16 colours for 8-Lite PRO2
Front aperture Ø:	680 x 395 mm	060983	Colour String, 11 colours for 8-Lite PRO2
Rear aperture Ø:	680 x 395 mm		
Power/data Connector style:	XLR4		
Weight:	8,5 kg		
Measurements:	519 x 830 x 98 mm		
Supply voltage:	24 V (PSU)		

### Maxi PSU

The Maxi PSU is power supply and DMX splitter for 24 “small” Colour Changers (6”, 8” and 12” PRO2) or 12 “big” units (15” and 8-Lite PRO2). The unit is delivered with M10 bold and mains cable with mounted Schuko plug; data cable is not included.

Technical data		Art.No.	Description
Supply voltage:	230 V (E); 110 V (U)	RCC125E	Maxi PSU, 230 V
Amount of scrollers per PSU:	12/24	RCC125U	Maxi PSU, 110 V
Mains connector:	CEE 22	270410	Halfcoupler 2” Lightweight
Output connectors:	4 x XLR4	270704	Safety cable 2 mm, 60 cm
Weight:	3,5 kg		
Measurements:	293 x 82 x 250 mm		

### Micro PSU

The Micro PSU is power supply and DMX splitter for 6 “small” Colour Changers (6”, 8” and 12” PRO2) or 3 “big” units (15” and 8-Lite PRO2). The unit is delivered with M10 bold and mains cable with mounted Schuko plug; data cable is not included.

Technical data		Art.No.	Description
Supply voltage:	85-260 V	RCC141	Micro PSU
Amount of scrollers per PSU:	3/6	270410	Halfcoupler 2” Lightweight
Mains connector:	CEE 22	270704	Safety cable 2 mm, 60 cm
Output connector:	1 x XLR4		
Weight:	1,4 kg		
Measurements:	178 x 72 x 136 mm		



**Worldwide Distribution:**  
**Rainbow Colour Changers GmbH**  
An der Talle 26-28  
D-33102 Paderborn  
Germany

Tel.: +49 (0) 52 51/14 092-28  
Fax: +49 (0) 52 51/14 092-90

[www.rainbow-colour-changers.de](http://www.rainbow-colour-changers.de)  
[info@rainbow-colour-changers.de](mailto:info@rainbow-colour-changers.de)

©2007 Rainbow Colour Changers GmbH  
Rainbow is a registered trademark of  
Rainbow Colour Changers GmbH

This manual is valid from the 1<sup>st</sup> of July 2007. All previous manuals are herewith not valid any longer.

All technical specifications are subject to change without notification.

**German Distribution:**  
**Lightpower GmbH**  
An der Talle 26-28  
D-33102 Paderborn  
Germany

Tel.: +49 (0) 52 51/14 32-0  
Fax: +49 (0) 52 51/14 32-80

[www.lightpower.de](http://www.lightpower.de)  
[info@lightpower.de](mailto:info@lightpower.de)